

# SWA – HI-SPEED MODULE

Stern presents the BTM series soap-water-air hi-speed modular system for integration behind the mirror. Operated by IR sensor. Includes touch-free faucet, touch-free soap or foam dispenser and hi-speed hand dryer.

- Complete system including high speed hand dryer, thermostatic mixing valve, touch free faucet, liquid soap dispenser and optional lamp soap level indicator.
- Ready to be integrated behind the mirror for a clear, minimalistic design.
- Eliminates messy, slippery floors and hand drying queues.
- Reduces the amount of labor for commercial facilities maintenance.
- Easy installation with a stainless steel frame to be fixed to the wall.
- Ideal touch free soap-water-air cycle.
- Helps preventing cross contamination.
- Reduces water and soap consumption.
- To be used with non-proprietary soap.
- Drying time: less than 15 seconds.



## ADVANTAGES



LEED RATING



SOAP AND WATER



GERM FREE



ADJUSTABLE SETTINGS



EASY TO INSTALL



CLOGGING FREE



ADA DESIGNED

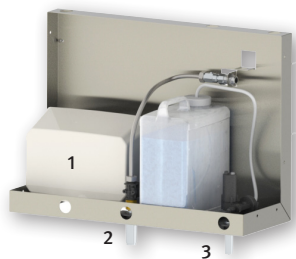

Modular system including high-speed hand dryer (1), touch-free faucet (2) and liquid soap dispenser (3)

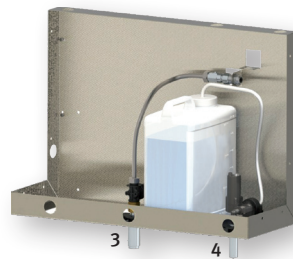

Modular system including touch-free faucet (3) and liquid soap dispenser (4)

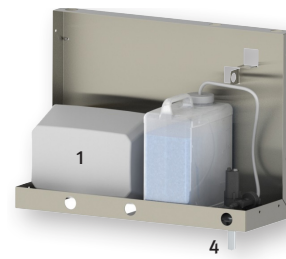

Modular system including high-speed hand dryer (1) and liquid soap dispenser (4)

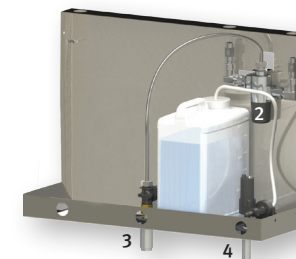

Modular system including thermostatic mixing valve (2), touch-free faucet (3) and liquid soap dispenser (4)

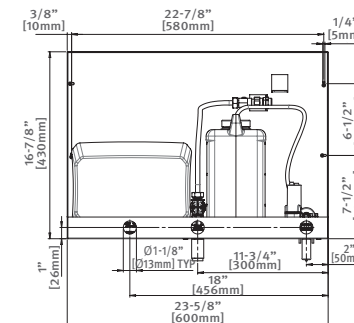

## ORDERING INFORMATION

| MODEL                 | CODE   | POWER           |
|-----------------------|--------|-----------------|
| SWA – HI-SPEED Module | 280410 | 12V Transformer |

777 Passaic Avenue  
Clifton NJ, 07012  
USA: sternusa@sternfaucets.com  
International: info@sternfaucets.com  
Toll Free: 1-800-4364410  
www.sternfaucets.com