

# stern

STERN ENGINEERING LTD.



ELECTRONIC LAVATORY FAUCET  
**CLASSIC CS SERIES**

INSTALLATION AND MAINTENANCE GUIDE

# INDEX

1	TECHNICAL DATA
2-3	PACK CONTENTS
4	PRE-INSTALLATION INFO
4	MAINTENANCE <ul style="list-style-type: none"> <li>Filters cleaning instructions</li> <li>Care and cleaning of chrome and special finishes</li> </ul>
5-7	FAUCET INSTALLATION
8-11	SETTINGS ADJUSTMENT
12-13	BATTERY REPLACEMENT
14	SPARE PARTS LIST
16	LIMITED WARRANTY
17	TROUBLE SHOOTING

# TECHNICAL DATA

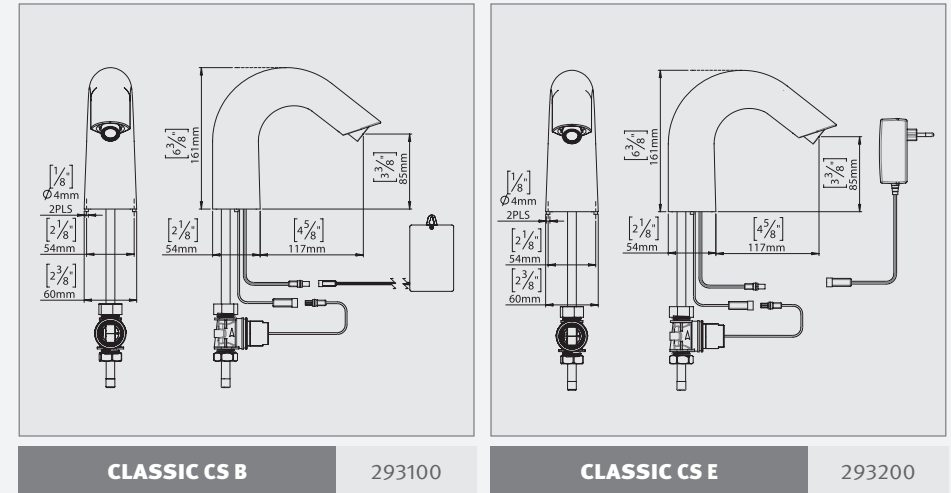

**CLASSIC CS B**

293100

**CLASSIC CS E**

293200

<b>Power supply</b>	6X1.5V batteries / 9V transformer
<b>Recommended water pressure</b>	0.5-8.0 bar (7-116 PSI) With water pressure of more than 8 bars, use a pressure reducing valve for reduction.
<b>Preset sensor range</b>	100 mm Adjustable with remote control
<b>Minimum sensor range</b>	30 mm
<b>Maximum sensor range</b>	200 mm
<b>Security time</b>	90 seconds.
<b>Hot water temperature</b>	Max 70°C

## PACK CONTENTS

Familiarize yourself with the part names and confirm that the parts are included.

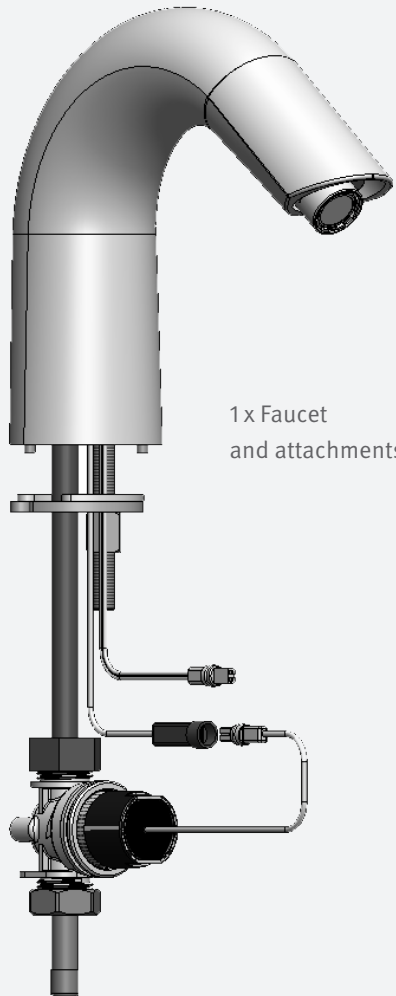

1 x Faucet  
and attachments



1 x Allen Key

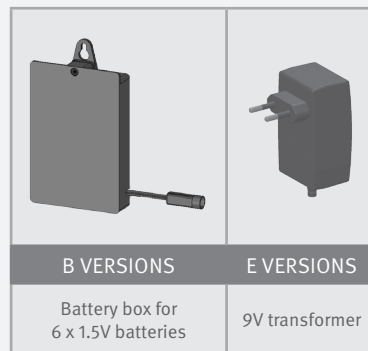

## PRE-INSTALLATION INFO

### CHECK CONTENTS

Separate all parts from the packaging and check each part with the “Pack contents” section. Pay attention to the different models variations.

Make sure all parts are accounted for before discarding any packaging material.

If any parts are missing, do not attempt to install your electronic faucet until you obtain the missing parts.

### WARNINGS

Do not install facing a mirror or any other electronic system operated by an infrared sensor. To prevent reflection problems, it is recommended to keep a minimum distance of 1.50 meters between the faucet and any other objects.

### PREPARATION FOR INSTALLATION

Flush water supply lines thoroughly before installing the faucet. Do not allow dirt, Teflon tape or metal particles to enter the faucet. Shut off water supply.

**IMPORTANT:** All plumbing is to be installed in accordance with applicable codes and regulations.

RECOMMENDED HOLE SIZE



## MAINTENANCE

### Filter cleaning instructions

This faucet is provided with a stainless steel filter preventing foreign particles to enter the lines. If the water flow has decreased, this can be because the filter is clogged. The filter can be cleaned as follows:

1. Shut-off the water shut off valve (angle valve).
2. Disconnect the flexible pipe/s.
3. Remove the filter and wash it under running water.
4. Reassemble the parts.
5. Make sure that there is no water leakage.

### Care and cleaning of chrome and special finishes

**DO NOT** use steel wool or cleansing agents containing alcohol, acid, abrasives, or the like. Use of any prohibited cleaning or maintenance products or substances could damage the surface of the faucet. For surface cleaning of faucet use **ONLY** soap and water, then wipe dry with clean cloth or towel. When cleaning bathroom tile, the faucets should be protected from any splattering of harsh cleansers.

## FAUCET INSTALLATION

### STEP 1 – PREPARATION FOR MOUNTING THE FAUCET

1 Shut off the water supply.

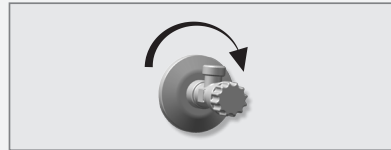

2 Remove the hexagonal nut, the disk and the gasket. Do not remove the O-ring from the base of the faucet.

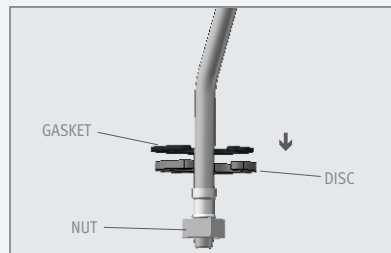

### STEP 2 – INSTALLING THE FAUCET

1 Place the faucet with O-ring into the hole in deck or lavatory. Make sure the O-ring is located between the deck or lavatory and the bottom of the faucet.

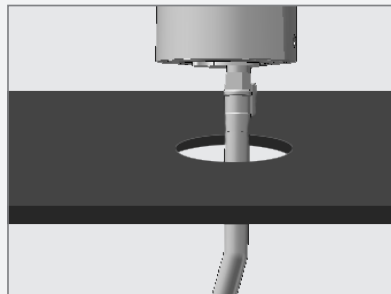

2 Below the deck, slide the gasket, disk and hexagonal nut over the flexible hose and secure the faucet into place.

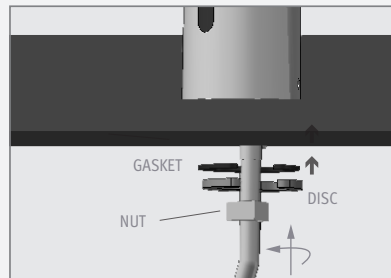

## FAUCET INSTALLATION

### STEP 3 – CONNECTING THE WATER SUPPLY

1 Connect the flexible pipe to the water supply. Make sure the filter is installed between the flexible hose and the shut off valve (angle valve - not supplied).

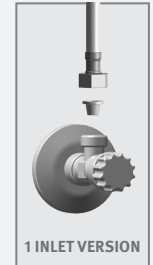

2 Turn on the central water supply and the shut-off valves (angle valves) and check for leaks.



### STEP 4 – CONNECTING THE POWER SOURCE

**If your model is classic CS B:** install the battery box underneath the sink with the cable connection pointing down and connect the connectors.

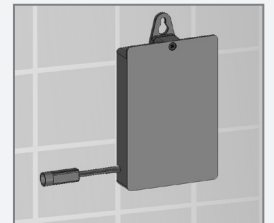

**If your model is Classic CS E:** Plug the transformer into the electricity socket and connect the connectors.



## FAUCET INSTALLATION

2

Remove the protective sticker from the sensor

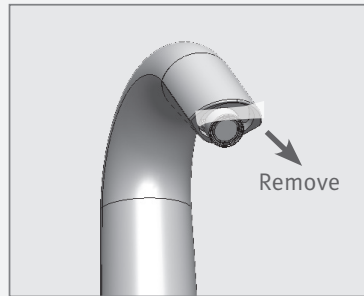

3

Wait a few seconds before activating the faucet. If the range is unsatisfactory, refer to the section titled "Settings adjustment".



## SETTINGS ADJUSTMENT



### Adjusting the settings with the remote control

If necessary, the sensor settings can be adjusted as following:

Shut off the water supply. In order to adjust the sensor with the remote control, hold the remote control straight in front of the sensor in a distance of about 6-8" (15-20cm). Choose the function you want to adjust by pressing once on one of the function buttons. After pressing once on a specific function button, a quick flashing of the red light at the front of the sensor will occur. At this stage, you can change the setting by pressing the (+) or the (-) buttons, every push will increase or decrease one level. After finishing the adjustment, turn the water supply back on.

## SETTINGS ADJUSTMENT



**DETECTION RANGE:** This faucet was supplied with a self adjusting sensor. The ideal detection range for the specific location will be set automatically.

Only if necessary, use the remote control to adjust the sensor range as follows:

Press the RANGE button. Wait until a quick flashing of the red light in the sensor eye is perceived. Then, press + to increase the range and – to reduce it. Every push will increase or decrease one level.

Note: Once you have changed the detection range with the remote control, the distance will be remembered by the sensor, even if the power source is disconnected. To get back to the self adjustment mode, use the ADJ button only.



**ENTRANCE TO THE SELF ADJUSTMENT MODE:** Check that no objects are in front of the sensor. Press the ADJ button. Once a quick flashing of the red light of the sensor eye is perceived, remove your hand holding the remote control and move away from the sensor area. The ideal sensor range for the specific location will be set automatically. Once the self adjustment has taken place, the solenoid valve will be opened and closed for 1 second as an indication that the ideal sensor range was set and the product is ready for use.



**SECURITY TIME:** The Security time, prevents continuous running of water due to reflections or vandalism. By default, if the sensor is covered for more than 90 seconds the water flow will shut automatically. To resume regular operation any obstruction must be removed.

Press the SEC button. Wait until a quick flashing of the red light in the sensor eye is perceived. Then, press + to increase the security time and – to reduce it.

## SETTINGS ADJUSTMENT



**DELAY IN TIME:** It is recommended to change the delay in time for flush valves for urinals or toilets only.

If required, the delay in time can also be modified in faucets as follows:

Press the IN button. Wait until a quick flashing of the red light in the sensor eye is perceived. Then, press + to increase the delay in time and – to reduce it.



**DELAY OUT TIME:** This button allows modifying the water flow time after the user removes his hands from the faucet. A delay out time close to 0 will save more water. An increased delay out time will make the user experience more comfortable.

If required, the delay out time can be modified as follows:

Press the OUT button. Wait until a quick flashing of the red light in the sensor eye is perceived. Then, press + to increase the delay out time and – to reduce it.



**24 HOUR HYGIENE FLUSH:** This model includes a 24 hours hygiene flush which is disabled. To activate the hygiene flush, press the clock button. Wait until a quick flashing of the red light in the sensor eye is perceived. Then press + to activate the hygiene flush. To disable it again, press – to deactivate it.



**COMFORT FLUSH:** If your model includes a Comfort flush setting, it can be activated by pressing the flush button.

When the button is pressed, one blink of the blue light in the sensor eye is perceived. The pre-programmed flush cycle will take place then.

The Comfort flush cannot be interrupted or deactivated by pressing any button until it is over.



**TEMPORARY OFF FUNCTION:** This function is ideal to perform any kind of activity in front of the sensor without operating the system (for example, cleaning).

The faucet will remain shut for 1 minute when this button is pressed once. To cancel this function and to return to normal operation press the On/Off button again or wait 1 minute.



**RESET BUTTON:** This function restores all the factory settings except for the sensor range. If required, press the Reset button and without releasing it, press the + button once.

**NOTE:** To enter the self adjusting mode, use the ADJ button. To change the sensor range, use the RANGE button.

## BATTERY REPLACEMENT

When the battery weakens, the red indicator light will blink at a constant rate. The battery must be replaced within two weeks.

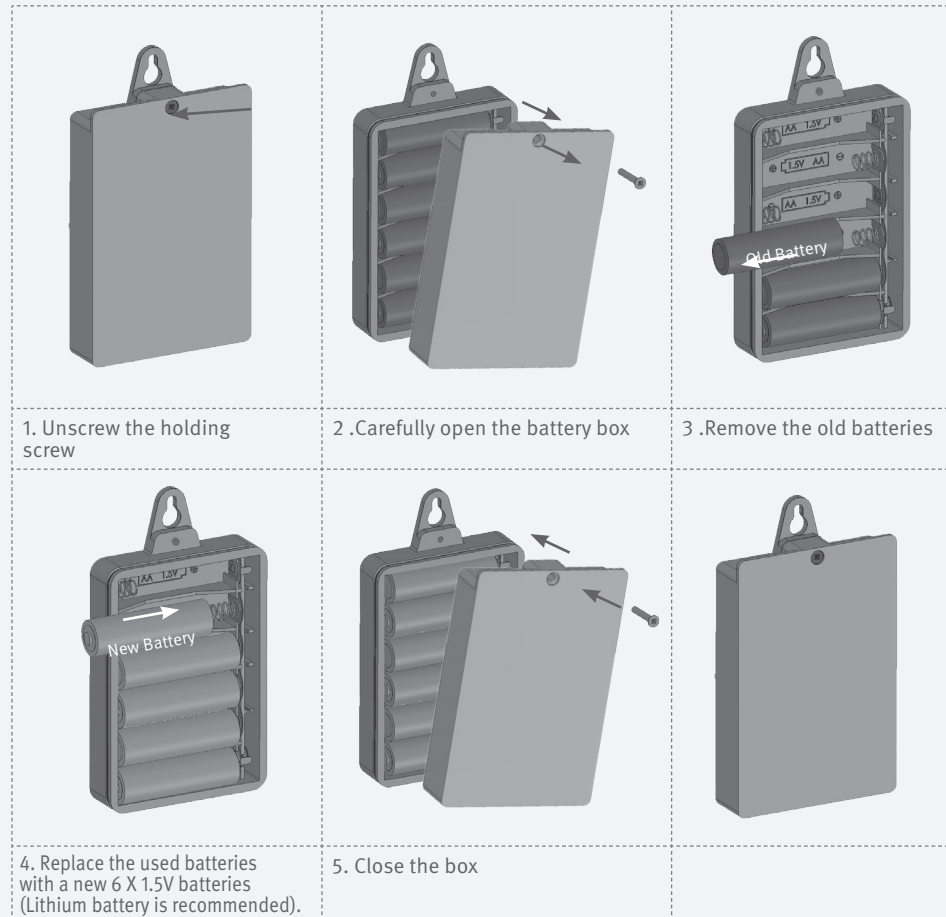

**IMPORTANT:** Spent batteries should not be disposed of with normal household waste. Contact your local authority for information on waste disposal and recycling.



## SPARE PARTS LIST

Seals and Screws Kit for Classic models	07210157
10-Pack Sensor kit	07220411
10-Pack Solenoid valve kit	07232000
Filter	08530014
Battery box	06530092
12-Pack 9V transformer	06540002
Insert Kit for Classic models	07240047
Remote control (Optional)	07100005

## LIMITED WARRANTY

Y. Stern Engineering Ltd. warrants that its electronic products will be free of defects in material and workmanship during normal use for two years from the date the product is purchased.

If a defect is found in normal use, Y. Stern Engineering Ltd. will, at its discretion, repair, provide a replacement part or product, or make appropriate adjustments. Damage caused by accident, misuse, or abuse is not covered by this warranty. Improper care and cleaning will void the warranty. Proof of purchase (original sales receipt) must be provided to Stern Engineering Ltd. with all warranty claims.

Stern Engineering Ltd is not responsible for labor charges, installation, or other incidental or consequential costs other than those noted above. In no event shall the liability of Stern Engineering Ltd. exceed the purchase price of the product.

If you believe that you have a warranty claim, contact your Stern Distributor, Dealer or Plumbing Contractor. Please be sure to provide all pertinent information regarding your claim, including a complete description of the problem, the product, model number, the date the product was purchased, from whom the product was purchased and the installation date. Also include your original invoice.

Y. STERN ENGINEERING AND/OR SELLER DISCLAIM ANY LIABILITY FOR SPECIAL, INCIDENTAL OR CONSEQUENTIAL DAMAGES. This warranty excludes product damage due to installation error, incorrect maintenance, wear and tear, battery, product abuse, or product misuse, whether performed by a contractor, service company, or the consumer. This warranty does not cover product damage caused by the following:

- Incorrect installation.
- inversions of supply pipes.
- Pressures or temperatures exceeding recommended limits.
- Improper manipulation, tampering, bad or lapsed maintenance.
- Foreign bodies, dirt or scale introduced by the water supply or soap tank.
- Use of the soap outside of viscosity specifications.
- Alteration of the original soap/foam dispenser components (including pipes).

## TROUBLESHOOTING

PROBLEM	INDICATOR	CAUSE	SOLUTION
No water coming out of the faucet:	1. Sensor flashes continuously when user's hands are within the sensor's range.	Low battery.	Replace battery
	2. Red light in the sensor does not flash once when user's hands are within the sensor's range.	1. Range is too short.	Increase the range
		2. Range is too long.	Decrease the range
	3. Red light in the sensor flashes once when user's hands are within the sensor's range.	3. Battery is completely used up	The battery must be replaced.
		4. Unit is in "Security Mode"*	Eliminate cause of reflection.
Water flow from spout does not stop:	1. Sensor flashes once when user's hands are within the sensor's range.	1. Connectors between the electronic unit and solenoid are disconnected.	Connect the electronic unit connectors to the solenoid.
		2. Debris or scale in solenoid.	Unscrew solenoid, pull out the plunger and the spring from the solenoid and clean them. Use scale remover material if needed. When replacing the plunger, please make sure that the spring is in vertical position.
	2. Red light in the sensor does not flash once when user's hands are within the sensor's range.	3. The central orifice in the diaphragm is plugged or the diaphragm is torn	Clean the orifice or replace diaphragm.
		4. The water supply pressure is higher than 8 bar.	Reduce the supply water pressure.
		5. The water supply pressure is under 8 bars and yet the pressure in the faucet's body is higher. This situation could be caused by a sudden increase in the water supply pressure that the back check prevents from dropping, even after water supply pressure drops under 8 bars.	Shut off water supply and unscrew one of the flexible pipes in order to reduce the pressure that blocks the product.
Water flow diminished	1. Sensor flashes once when user's hands are within the sensor's range.	Debris or scale in diaphragm	Clean the orifice or replace diaphragm.
		2. Red light in the sensor does not flash once when user's hands are within the sensor's range.	1. Sensor is dirty or covered.**
		2. Sensor is picking up reflections from the washbasin or another object.	Decrease the range or eliminate cause of reflection.
		Filter or aerator is clogged	Remove, clean, re-install

\* "Security Mode": If the sensor is covered for more than 90 sec. the faucet will automatically shut off water flow. To return to normal operation remove any blockage.

\*\* In this case, the water flow will stop anyway after 90 seconds because of the security time.



# stern

STERN ENGINEERING LTD.

777 Passaic Avenue, Clifton NJ, 07012, USA

Tel: +1-973 773 8011 | Fax: +1-973-779-8768

Toll Free: 1-800-4364410

[info@sternfaucets.com](mailto:info@sternfaucets.com) | [tech@sternfaucets.com](mailto:tech@sternfaucets.com)

